

## MAINTENANCE

Your Micro Fence has been thoroughly checked during its assembly for smooth and accurate operation. There are a number of alignments and tension adjustments that are critical to the unit's proper functioning. In the normal course of use, you may need to check these settings and re-adjust them if necessary.

### Checking parallel alignment of the guide shafts

The guide shafts (either 7" or 12") must be parallel to one another in both horizontal and vertical planes (see Fig 1, #9). Test the vertical alignment by simply placing the mounting bar and guide shaft assembly on a smooth, flat surface (a table saw, jointer bed, etc.), and tap lightly on the end of each guide shaft with the tip of your finger. Any motion indicates a misalignment that will adversely affect the way in which the shafts slide through the body and spindle bar.

**Fig.4**

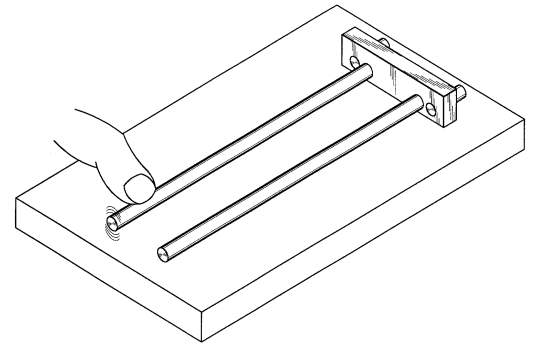

Apply pressure to the guide shaft in the appropriate direction to correct the misalignment and re-test on the flat surface. Pay special attention to insure that the readjustments have not loosened the shafts in the mounting bar. If necessary, re-tighten, using the rubber pad and either your fingers or pliers to achieve firm tightness.

The horizontal alignment can be checked visually by simply installing the guide shafts in the main body of the Micro Fence. They should slide into the Delrin bushing without deflection, and pass on through the appropriate holes in the spindle bar without significant resistance, (though a little is OK). Fluid motion should be checked by sliding the guide shaft/mounting bar assembly back and forth a few times.

Be sure to tighten all threaded parts. A loose guide shaft will compromise the rigidity of your edge guide. This holds true for the mounting pins as well. **Keep all threaded parts firmly seated.**

### Adjusting torque of the Lock Nut and Wave Washer

The "feel" (tightness or looseness) of the adjustment screw (spindle) can be set by increasing or relieving the compression of the wave washer (Fig 1, #15), located between the two Delrin thrust washers (Fig 1, #14) under the nylock nut (Fig 1, #16). The lock nut requires a 7/16" wrench. The more tightly compressed the wave washer is, the stiffer the feel of the spindle as it turns. If excessively loosened, lateral deflection of your fence is possible. As a rule, the nylock nut should be as tight as possible without making the spindle uncomfortably difficult to turn with your thumb and forefinger.

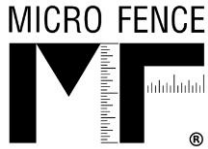

## **MICRO FENCE EDGE-GUIDE SYSTEM**

12970 Branford Street Unit M, Arleta, CA 91331 Phone 1-800-480-6427  
Email: [microfence@microfence.com](mailto:microfence@microfence.com) Website: [www.microfence.com](http://www.microfence.com)

### **Cleaning your Micro Fence**

Keep your Micro Fence as clean and dust-free as possible with compressed air or a soft brush. An occasional drop of light oil under the spindle lock thumbscrew will keep the lead screw turning smoothly. Our choice is Phil's Tenacious Oil which can be purchased from us in 5cc sample or 4oz. bottles. We recommend cleaning and lubricating the stainless steel guide shafts with a good silicone-free dry lubricant. At our factory, we use Dynaglide during the assembly process. If you wish, it can be ordered directly from us by calling **800-480-6427**.

### **Router adjustments**

Router motors operate at high rpm, and typically are prone to vibration from even slight misalignments. Collet wear and accumulated dirt can have a negative effect on the way the bits rotate and cut. Other factors that affect a router's cutting quality include the sharpness and accuracy of the bits' edge grind, and concentricity of the bits' cutting surface relative to the shank. Keep your router clean and in good working order and buy only good quality router bits. Use only sharp bits. (Easy-Off oven cleaner works well to remove pitch.)

Under normal circumstances, the brass thumbscrews that lock the stainless steel guide shafts and adjustment-screw spindle should withstand router vibration and hold fast. However, if there's lots of vibration (some routers simply vibrate more than others), the thumbscrews may loosen and subsequently cause your edge-guide to slip out of position. If this occurs, we strongly recommend first checking the router's collet for wear. Improper bit installation or over tightening can cause the collet to become "sprung", and affect its gripping capability or the trueness of the bits' rotation. Installing a slice of rubber tubing with ¼" I.D. under the heads of the thumbscrews can help to absorb excess vibration and prevent inadvertent loosening.

It is normal for the brass lock-screws on your Micro Fence to tarnish. Their original luster can be restored by polishing them with fine steel wool or Scotchbrite abrasive pads. We use a drill press or cordless drill with hand-tightened chuck to spin them while firm pressure is applied with the polishing material.

### **Replacing wood fences**

You can make your own wooden replacement fences, (or order them from us directly--**800-480-6427**). The wooden fences are attached with 8-32 X ½" fillister head screws. They are positioned on 2" centers and require 3/16" through holes with ¼" counter-bores, 3/16" deep.

**Tip:** *Use the hole spacing of your Micro Fence's stock wood fences as a pattern or template when making new or custom fences.*