



**Micro Fence®**, with its micrometer measuring advantage, now offers an accessory package that works in conjunction with the **Festool FS Guide Rail System** to provide dados of any size placed at any position on your work surface.

This new accessory utilizes the front trammel portion of our **Circle Jig**, the **Universal Router Plate** (you drill to match your router's base), and a **UHMW sliding fence** that conforms to the shape of the guide rails' aluminum extrusion. The resulting combination provides a method of dadoing with unprecedented ease, measuring capability and control. The Universal Router Plate is standardized to work with our **Model A mounting bar**. The photo at left also shows our **Stabilizer Bar** installed. We recommend its use for maximum rigidity.

See page 2 of these instructions for an exploded view of the assembly pictured above and the parts included with this accessory.

**Initial Setup:** Pre-set your **Micro Fence®** dial at 50. Clamp the guide rail to the surface of some scrap material and place the Router plate/Circle Jig assembly in position as shown in the photo above. Loosen the brass thumbscrews and slide the guide shafts and router plate back as close as possible to the edge of the clamp. Retighten the brass thumbscrews firmly.

One initial cut will tell you what the offset dimension will be for your particular router's setup. Once this is known, pencil marks can be placed for aligning the guide rail in proper position to place your cut where you wish it to be. After measuring the cut size with calipers, the usual **Micro Fence®** procedures can be followed to adjust the size of the dado to any size you desire. Don't forget to include whatever tolerance your job may require.

The Festool Guide Rail interface can be used for dadoing, straightening uneven edges or preparing two edges for glue up (finger joint or glue-joint bits can be used for these applications).

This drawing shows the forward trammel assembly of the CJA and the standard 7" guide shafts from the basic edge guide. (Longer guide shafts could conceivably be used as well). The same Universal Router Plate and Riser Block Assembly are used in our Ellipse Packages.

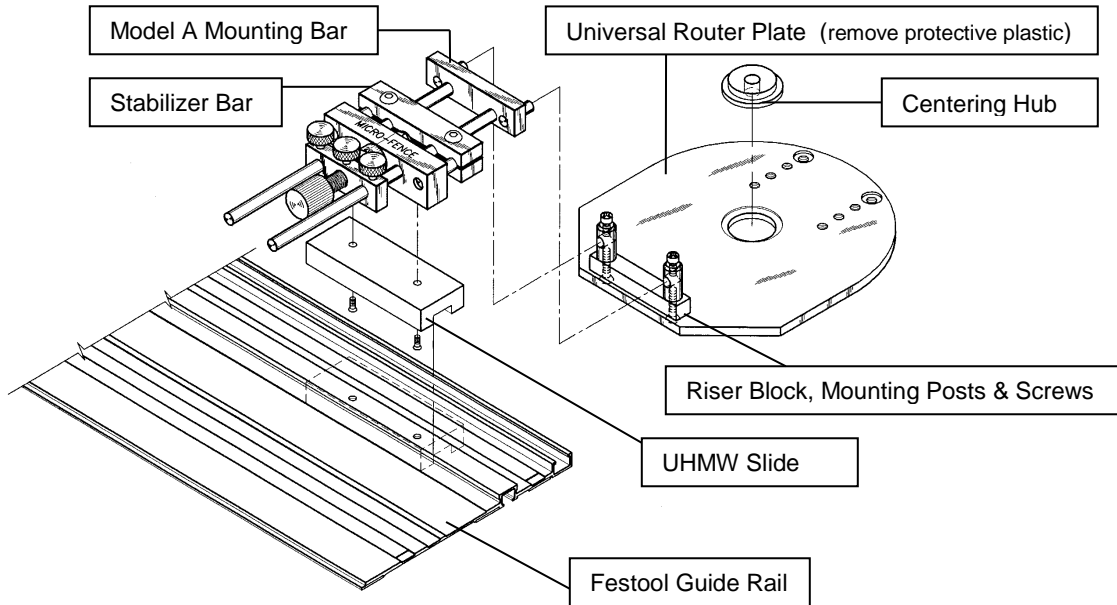

**Parts List for this Micro Fence® Accessory:**

- Universal Router Plate (you drill to match your router's base)
- Riser Block
- Mounting Posts and screws
- UHMW Slide and screws (this part is all you'll receive if you already have the Ellipse Jig)
- Model A Mounting Bar (not included with this package)
- Centering Hub
- Stabilizer Bar (Recommended Accessory)

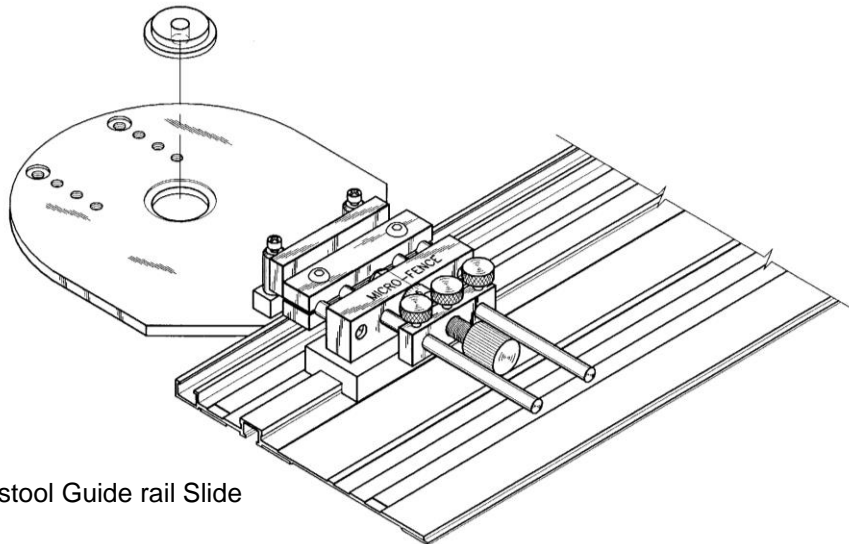

View of assembled Festool Guide rail Slide

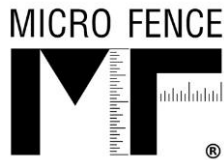

## Festool Guide Rail Slide

12970 Branford Street Unit M, Arleta, CA 91331 Phone 1-800-480-6427  
Email: [microfence@microfence.com](mailto:microfence@microfence.com) Website: [www.microfence.com](http://www.microfence.com)

Each Universal Router Plate comes with an aluminum Centering Hub to assist you in properly mounting your router on the Plate. This centering hub is made to fit the most popular template guide bushing recesses in router sub-bases (1.375").\*

Seat the hub in the template guide bushing recess of the **Micro Fence®** Plate as shown in the exploded-view diagram above. (The 1.375" diameter should be facing upward).

Remove the manufacturer's plastic sub-base from the bottom of your router and place it over the Centering Hub to locate it on the **Micro Fence®** Router Plate. Pay attention to keep the sub-base bottom-side down and to position the mounting holes so that the router will mount in the posture you prefer.

(Some considerations are the position of the handles in relation to the edge-guide, 90° being the generally accepted preference; and the position of the plunge lock on the router in relation to whether you are right or left-handed).

**\*If the opening in your sub-base is *not* 1.375" and cannot be fitted with the Centering Hub, try installing a 1/4" router bit or drill in the router's collet and use the through hole in the middle of the Centering Hub to position and mark the hole positions for your router base.**

We suggest that you clamp the sub-base in the desired position and use it as a template to drill thru holes in the Universal Router Plate. After drilling, remove the clamps and the Centering Hub, turn the Universal plate over and countersink, (or counter-bore), the thru holes deep enough to allow the manufacturer's base screws to engage at least several threads into the 3/8" thick Universal Router Plate. The heads of these screws, of course, should not seat proud of the plate's bottom surface.

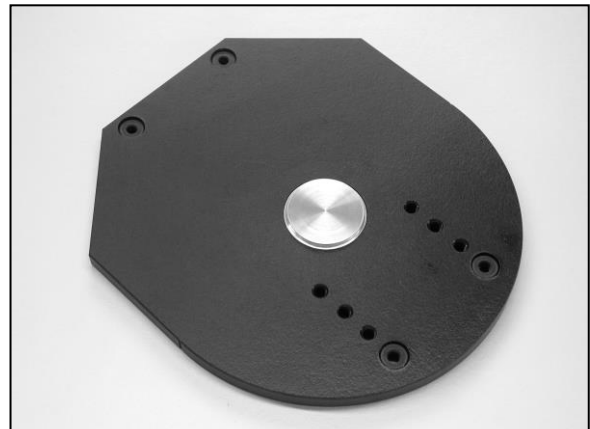

1/4" through hole in Centering Hub not shown

