

STABILIZER BAR INSTRUCTIONS

Our **Stabilizer Bars**, when installed across all four guide shafts of our **Circle Jig**, provide maximum rigidity for any operation, particularly heavier cut requirements, or when mounted on larger routers. If your intention is to cut circles in a single pass without first "blanking out" with a band saw or saber saw, the **Stabilizer Bar** will assist you in making accurate and smooth cuts.

They may be positioned in front of, or behind the spindle bar depending on your work requirement. For longer extensions, position the stabilizer in front of the spindle bar by installing the two 1 1/2" pins included in your CJA parts bag). When your final adjustments are set, tighten the two wing-nut screws evenly. The **Stabilizer** is made of aluminum so it will not harm the stainless steel guide shafts.

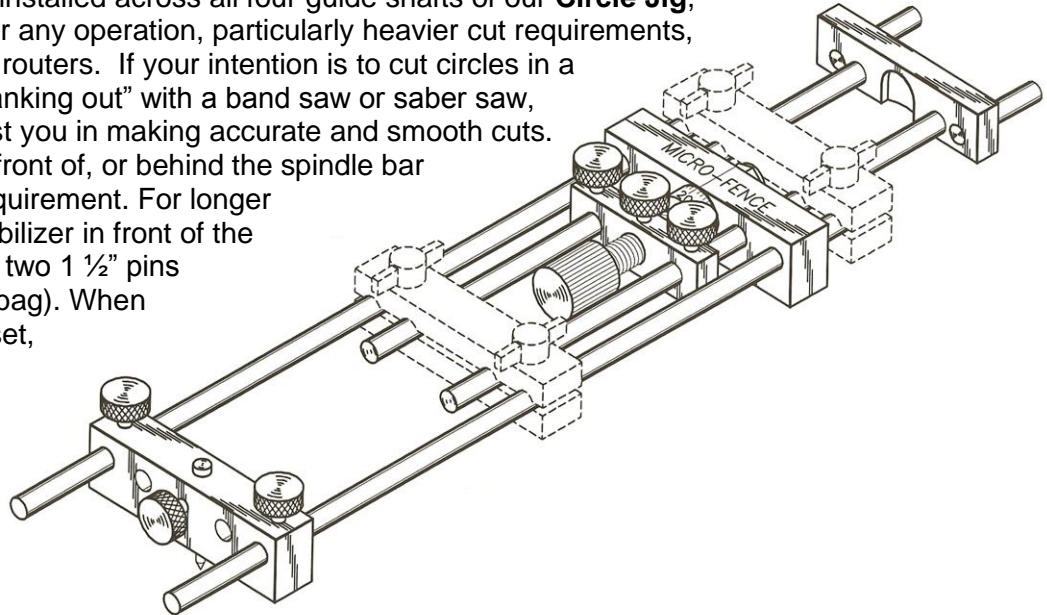

MICRO FENCE® 12970 Branford St. Unit M, Arleta, CA 91331
Phone: (818) 683-0330 Web: www.microfence.com